

C4I-AM11



Developed especially for the Defense Forces, the military vehicles 4x4 enter with great ease in places with the most difficult access, being ideal for the accomplishment of the hardest missions.

BODY	
Cab	3 / 4 seats
ENGINE - CUMMINS ISF 2.8	
Level of Emissions	PROCONVE P5 / EURO III
No. of Cylinders / displacement	4 in line / 2.799 cm ³
Power	110 kW (150 cv) a 3.200 rpm
Torque	110 kw (150 cv) @ 3.200 RPM
ELECTRIC SYSTEM	
Voltage	24V
Batteries	2 x 12V / 55 Ah
Alternator	24V / 80 A
CLUTCH - ORGANIC - DRY SIGLE DISC	
Disc's Outer Diameter	300 mm
Actuation	Hydraulic
DRIVING TRANSMISSION	
Make/Model	EATON FS 4505E
No. of Gears	5 Forward 1 Reverse
TRANSFER CASE	
Model	Manual one Speed
SUSPENSION	
Front	Longitudinal and transversal bars with panhard
Rear	Longitudinal and transversal bars with panhard
Front/Rear Shock Absorbers	Double action, Telescopic
TRACTION AXLE	
Front	Agrale 8.9"
Type - Front	Floating - OPEN TYPE
Ratio - Front	4,56 : 1
Rear	DANA 70
Type - Rear	Rigid and floating axle with differential blocking Power Lock
Ratio - Rear	4,56 : 1

STEERING WHEEL	
Type	Hydraulic
WHEELSETS	
Model	7.00 x 16
TIRES	
Model	235/85 R16 ATR
BRAKES	
Service Brake - Type	Disc / Drum
Actuation	Hydraulic servo-assisted
Parking Brake - Type	Pedal with cab
SUPPLY CAPACITY	
Fuel Tank (Diesel S50)	100 L
Urea Tank (Arla 32)	NA
WEIGHTS AND CAPACITIES	
TGW - Total Gross Weight	3750 Kg
MTC - Maximum Traction Capacity	750 Kg
Kerb weight	3000 Kg
Load Capacity	750 Kg + 750 Kg (load + trailer)
Maximum Load of Front Axle	1.620 Kg
Maximum Load of Rear Axle	1380 Kg
FEATURES	
20L Gallon, Bull Bar, Canvas top kit - green, Fog Lights, Headrest , Heating System, Lights Protectors, Matte Green Color, Running Boards, SAPA Set	
OPTIONALS	
12 Poles Socket, 7 Poles Socket, Acelerador Manual, Camouflaged Color (Optional), Electric Wich, GPS, Inclinometer, Kit Tire 7.50X16 8L PTT, Kit Tire LT 235/85 R16, Montanha Brake, Mortar Chain, Remote Starting	

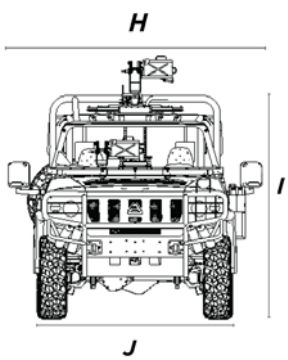
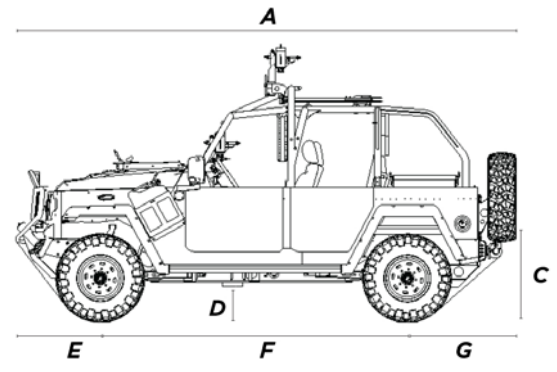
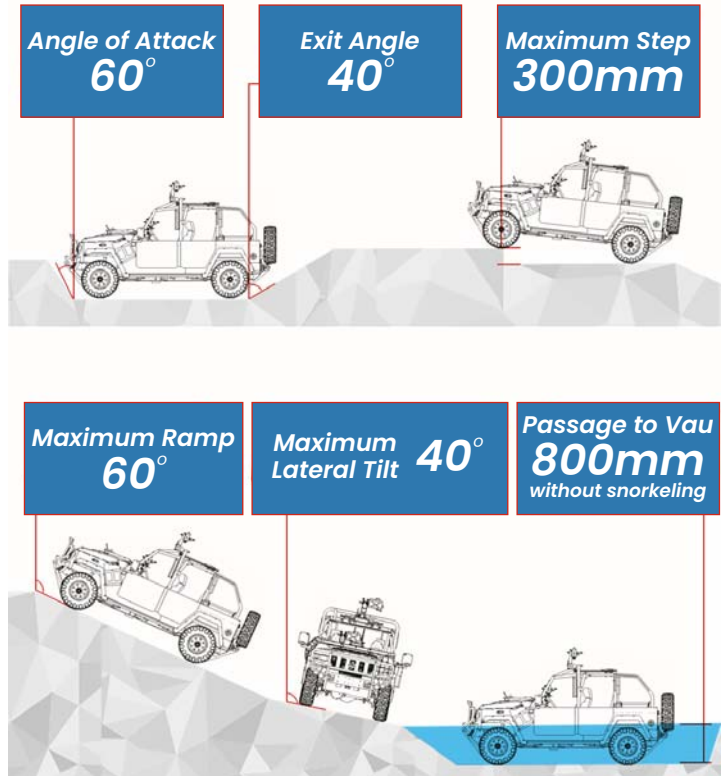

A	5290 mm
B	-
C	?? mm
D	340 mm
E	775 mm
F	2900 mm
G	1040 mm
H	2530 mm
I	2290 mm
J	1978 mm



LEARN MORE: c4communication.com
FOR MORE INFORMATION:
contact@c4communication.com or +1 (302)9811340