

C4I-AM21



C4I-AM21 - ¾ Ton, is a vehicle for transporting personnel or cargo of 750 kg. It has a hood, metal body and cabin with a canvas roof. Its strong and robust power train, the wide suspension travel and the resistance of the assembly, make this model an ideal utility to carry out military tasks in the most difficult terrain. Also available in RHD version (right hand drive)

BODY	
Cab	Simple - 2 seats
Dump	Metalic - 8 places
ENGINE - CUMMINS ISF 2.8	
Level of Emissions	PROCONVE P5 / EURO III
No. of Cylinders / displacement	4 in line / 2,799 cm ³
Power	110 kw (150 cv) @ 3.200 RPM
Torque	360 Nm 1.800 @ 2.700 rpm
ELECTRIC SYSTEM	
Voltage	12V
Batteries	2 x 12V / 70 Ah
Alternator	12V / 120 A
CLUTCH - ORGANIC - DRY SIGLE DISC	
Disc's Outer Diameter	300 mm
Actuation	Hydraulic
DRIVING TRANSMISSION	
Make/Model	EATON FS 4505 E
No. of Gears	5 Forward 1 Reverse
TRANSFER CASE	
Model	Agrale Manual One Speed 1:1 OPC.: Atlas Manual Two Speed 2:1 / 1:1
SUSPENSION	
Front	Longitudinal and transversal bars with panhard
Rear	Rigid axle
Front/Rear Shock Absorbers	Double action, Telescopic
TRACTION AXLE	
Front	DANA 44.3
Type - Front	Floating - OPEN TYPE
Ratio - Front	4,09 : 1
Rear	DANA 70
Type - Rear	Rigid and floating axle with automatic differential blocking Power Lock
Ratio - Rear	4,10 : 1

STEERING WHEEL	
Type	Hydraulic
WHEELSETS	
Model	7.00 x 16
TIRES	
Model	235/85 R16 ATR
BRAKES	
Service Brake - Type	Disco / Drum
Actuation	Hydraulic servo-assisted
Parking Brake - Type	Pedal with cab
SUPPLY CAPACITY	
Fuel Tank (Diesel S50)	100 L
Urea Tank (Arla 32)	NA
WEIGHTS AND CAPACITIES	
TGW - Total Gross Weight	4600 Kg
MTC - Maximum Traction Capacity	6585 Kg
Kerb weight	3195 Kg
Load Capacity	750 Kg + 750 Kg (load + trailer)
Maximum Load of Front Axle	1620 Kg
Maximum Load of Rear Axle	1575 Kg
FEATURES	
20L Gallon, Bull Bar, Dumpster canvas kit, Fog Lights, Headrest , Heating System, Lights Protectors, Matte Green Color, Running Boards, SAPA Set, Snorkel	
OPTIONALS	
12 Poles Socket, 7 Poles Socket, Acelerador Manual, Camouflaged Color (Optional), Electric Wich, GPS, Inclinomater, Kit Tire LT 265/85R16, Montanha Brake, Mortar Chain, Remote Starting	

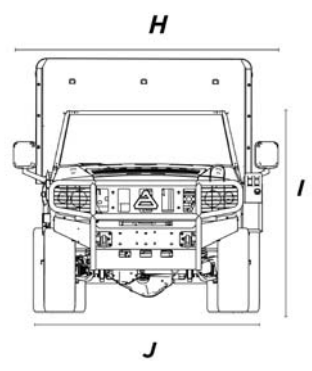
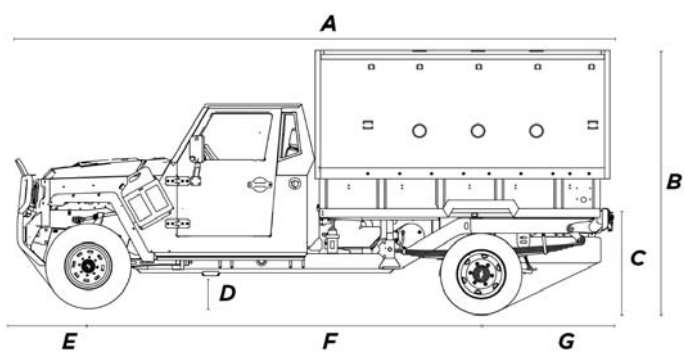
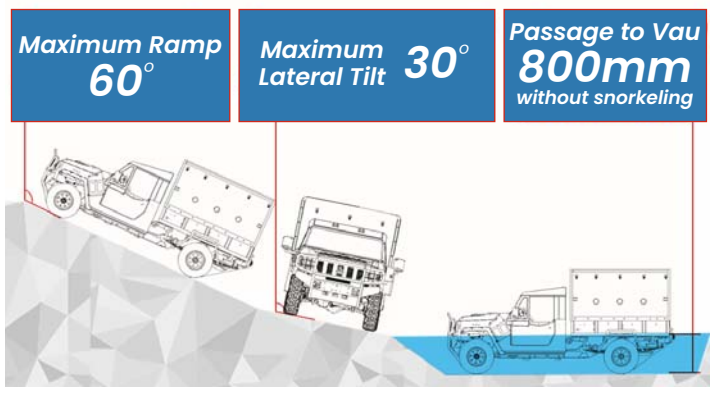
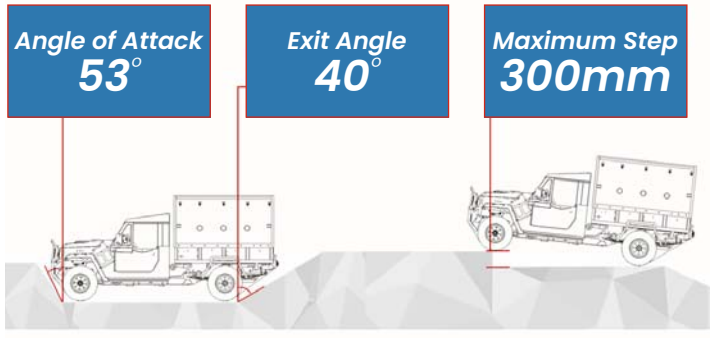

A	5620 mm
B	?? mm
C	1000 mm
D	310 mm
E	674 mm
F	3700 mm
G	1246 mm
H	2520 mm
I	1980 mm
J	2060 mm



LEARN MORE: c4icommunication.com
FOR MORE INFORMATION:
contact@c4icommunication.com or +1 (302)9811340