



Q4i
communication



C4i SENTRY® ARMORED PERSONNEL CARRIER



INTRODUCTION



The C4i Sentry APC is a light-weight armored personnel carrier specifically designed for border patrol and reconnaissance missions. Its high mobility, great maneuverability and survivability make it ideal for both highly dense urban settings, as well as rural theatres. With a selection of diesel and petrol engines, available in both LHD and RHD configurations, this highly versatile APC can be used globally. The C4i Sentry APC has three doors (one on each side and one on the rear) for ease of access and can seat up to 8 fully geared personnel. It can be equipped with a roof escape hatch and an optional turret system.

VEHICLE INFORMATION

ENGINE	4.0L, Petrol,V6 4.2L, Diesel,V6 4.5L, Diesel,V8
OUTPUT (Hp/rpm)	228/5200 129/3800 196/3300
TORQUE (Kg-m/rpm)	37/3800 285/2200 44/3200
TRANSMISSION	5-Speed Manual
DIMENSIONS	Length - 5270 mm Height - 2790 mm (With turret), 2320mm (Without turret) Width - 1870 (Mirror to mirror)
KERB WEIGHT	4,400 kg
WHEELBASE	3180 mm

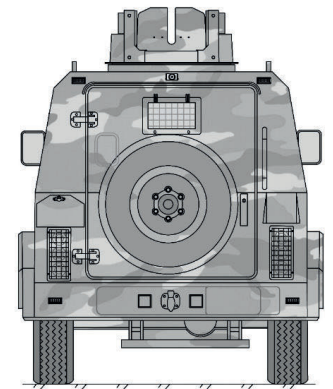
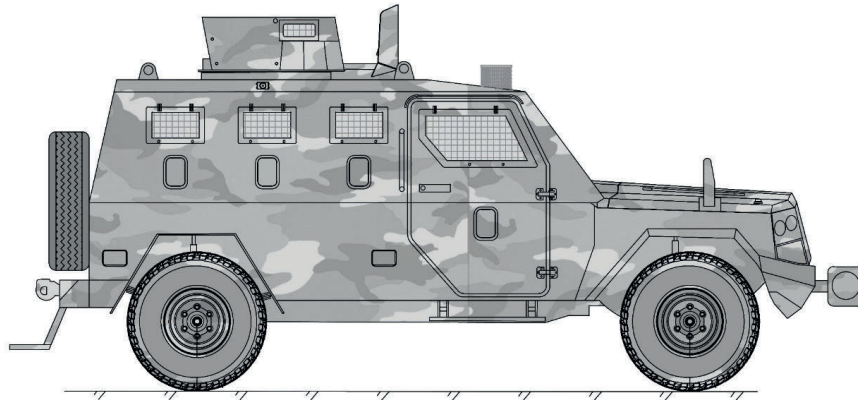
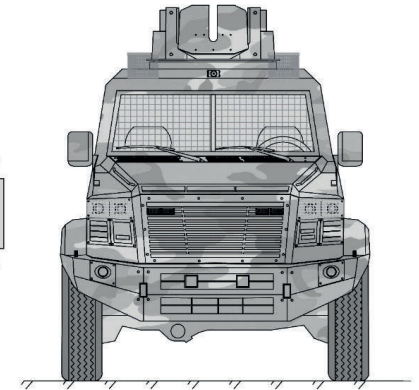
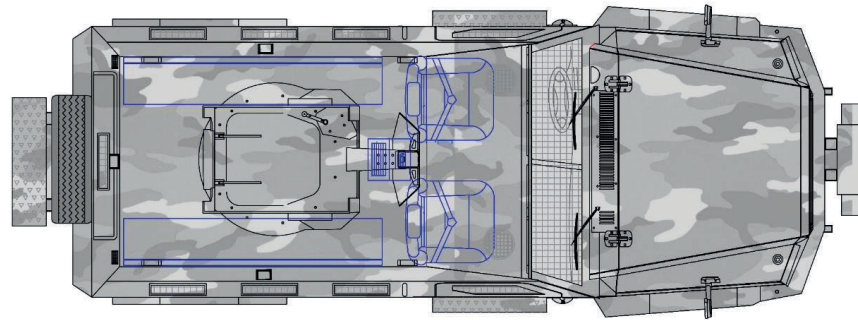

Note: The Drawing is for discussion purpose only the real vehicle may be different then depicted.

VEHICLE ARMORING: OVERVIEW



Full Vehicle armoring with certified CEN B6/NIJ III Level ballistic material, including front, sides, rear, roof, and floor, designed to resist incoming ballistic threats from any angle. Driver and all passengers are completely protected against explosive threats.

VEHICLE ARMORING: INTERIOR



- Seating capacity for 7 fully geared personnel plus driver
- All seats are equipped with 4-point seat harnesses
- Entry/exit points at both sides and rear of the vehicle
- Large ballistic glass panels provide optimal visibility of external environment
- Spring loaded gun-ports integrated at each seat to allow for defensive actions

INTERIOR ERGONOMICS



- Commercial SUV dashboard and controls for easy navigation and use
- Full entertainment system comprising of FM/AM radio and CD player
- Front and rear HVAC system
- 12V electrical system upgradable to 24V

OTHER FEATURES

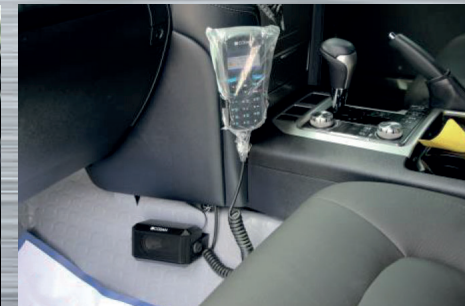

- Wire mesh protection
- Spare tire assemblies
- Jerry Can x 2
- Roof mounted turret
- Electric Winch with remote control
- 2-way PA (Public Address) System With Siren

- Gun ports
- Surveillance system
- Manual Fire suppression system for Engine
- Codan Envoy x1 Communication Package
- Motorola DM 4600 VHF system
- Iridium 9575 Extreme Full Kit Satellite Phone

CONTACTS



Bureau des États-Unis
2915 Ogletown road #1072
Newark, DE 19713 U.S.A
Tél: +1 (302) 981 1340
Fax: +1 (302) 380 3694



Bureau Maroc
219 Boulevard Zerktouni
BP 5277 – BAM Maârif
20330 Casablanca –Maroc
Tél: +212 (0)5 22 99 16 93
Fax: +212 (0)5 22 98 38 27



contact@C4icommunication.com



www.C4icommunication.com